

AAC-48L

AcousticAutoCalabrator

Quick Start Guide

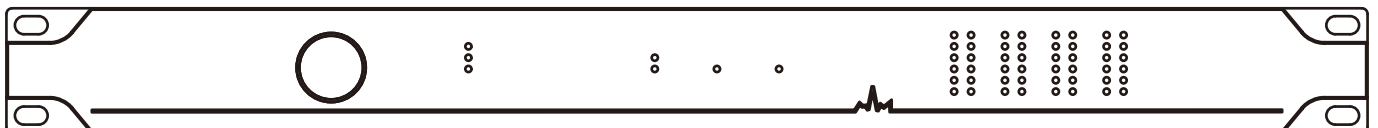



INDEX

1. Quick start guide

1.1 Packing list	3
1.2 System requirement	3
1.3 Technical support	3
1.4 Caution	4
1.5 Product overview.....	5
1.6 Product features.....	5
1.7 Device appearance	5

2. Install and connect

2.1 Devices connect and setup	6
2.2 Install ENEWAVE-AAC software.....	7

3 System configuration

3.1 Network connection.....	7
-----------------------------	---

4 General function introduction

4.1 Config speaker	8
4.2 Click APPLY CROSSOVER to load the crossover application	9
4.3 Connect the corresponding high and low frequency output.....	9
4.4 Sweep frequency.....	10
4.5 Click on the IMPLUSE interface	10
4.6 Enter usage mode	10
4.7 Use the CURVE interface to change the frequency amplitude	11
4.8 Corresponding display of phase	11
4.9 About compressor settings.....	12
4.10 Correct output items.....	12
4.11 Connection diagram of input and output	13
4.12 Save Settings	15

5 Specifications

6 Misunderstandings and precautions during use

7 Judgment and solution of failure

8 Real measurement environment



1 Quick start guide

1.1 Packing list

- One AAC-48L Acoustic Auto Calibrator
- One copy of quick start guide
- One flash driver or CD ROM with software, help files, quick start guide and specification sheet
- One IEC power cord

1.2 System requirement

- Computer with 1G Hz or higher frequency
- Mac OS or WINDOWS 7/8 and 10.
- 500 Mbyte free storage space
- 16-bit or higher resolution color
- 1G or more memory
- 1 Ethernet port
- Some of Cat-5e or Cat-6 Ethernet cable

1.3 Technical support

The help menu in the control software that comes with the machine contains detailed operating instructions and this quick guide. If you have any questions, you can contact the regional after-sales service in the following mail as

support@enewave.com



1.4 Caution

- Please read the instruction manual carefully before operating the device.
- Keep this manual properly for future reference.
- Remember and follow all safety instructions.
- Please place the device away from water sources.
- Clean the device by a dry cloth after unplugging the power plug.
- Please ensure that the vents of the device are not blocked.
- Please place the device away from heat sources.
- The power supply of the device must be grounded.
- Prevent the power cord from being trampled or dragged.
- Please use the accessories specified by the manufacturer.
- Please place the device in a stable location.
- Please unplug the power plug when it is not in use for a long time during a thunderstorm.
- If there is a malfunction, please consult or send it to a professional technician for treatment to prevent accidents. Do not open the chassis of the device for maintenance without authorization.
- Warning: do not place the device in rain and humidity to reduce the risk of fire or electric shock.
- Do not place the device in a dripping or splashing environment or under a water container.

Warning: To prevent electric shock, if you are not a professional technician, please do not open the device chassis to repair!

Electric shock mark: It reminds that if the power of the machine is not properly grounded, it may cause leakage and endanger personal safety.

Warning signs: remind users to strictly follow the specified steps.

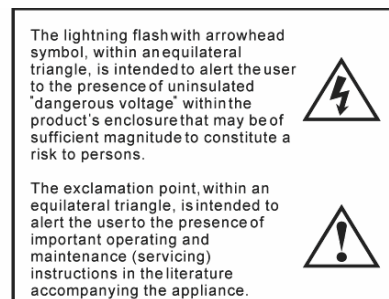



1.5 Product overview

The first space acoustics automatic calibrator that combines space acoustics and electroacoustic systems. It can optimize your acoustic environment, calibrate the frequency response of the audio system and acoustic space, perfectly show some sound details, and create an ideal acoustic space for you. The FPGA-based high-order real-time FIR acoustic phase calibration system breaks the barrier between digital audio algorithm technology and delay, and perfectly reproduces the essence of sound through the three-dimensional standards of sampling accuracy, sampling frequency and phase accuracy.

AAC aims to improve the clarity of the sound image and restore the transparency of the sound, thereby optimizing your acoustic environment. The system provides a variety of interfaces, exquisite design, simple to use, can meet the sound field measurement and calibration needs of various listening environments from small conference rooms, lecture halls, theaters, auditoriums, and large-scale live performances to achieve more transparency, high-resolution high-frequency performed and powerful bass.

The characteristics of the spatial acoustics automatic calibration processor are mainly reflected in

- Maximum processing order FIR minimum phase processing
- Digital audio equipment with the smallest delay
- The fastest tool for adjusting the acoustic environment

1.6 Product features

- High dynamic output.
- Built-in detection microphone multi-machine synchronization barrel input interface.
- Support multi-point measurement average.
- Free design of acoustic space frequency response.
- Automatic phase calibration.
- Compatible with two parallel two-channel high-order FIR filter processing at the same time. It can display the frequency response, pulse, phase curve in the acoustic environment.
- Reflection elimination processing tool that does not change the sound quality of the original speaker.
- Time processing tool that can gather energy for direct sound.
- Flexible matrix output selection.
- Each output has sampling point-level accurate delay and amplitude control functions.

1.7 Device appearance





2 Install and connect

2.1 Device connect and setup

- Connect the left and right stereo speakers to Main-L and Main-R respectively.
- The first subwoofer is connected to Sub-R and connect to Sub-L if you need to connect the second one.
- The network cable is connected to the router, and the computer program will control AAC through the network.
- Connect the measurement microphone to the XLR socket on the front panel.

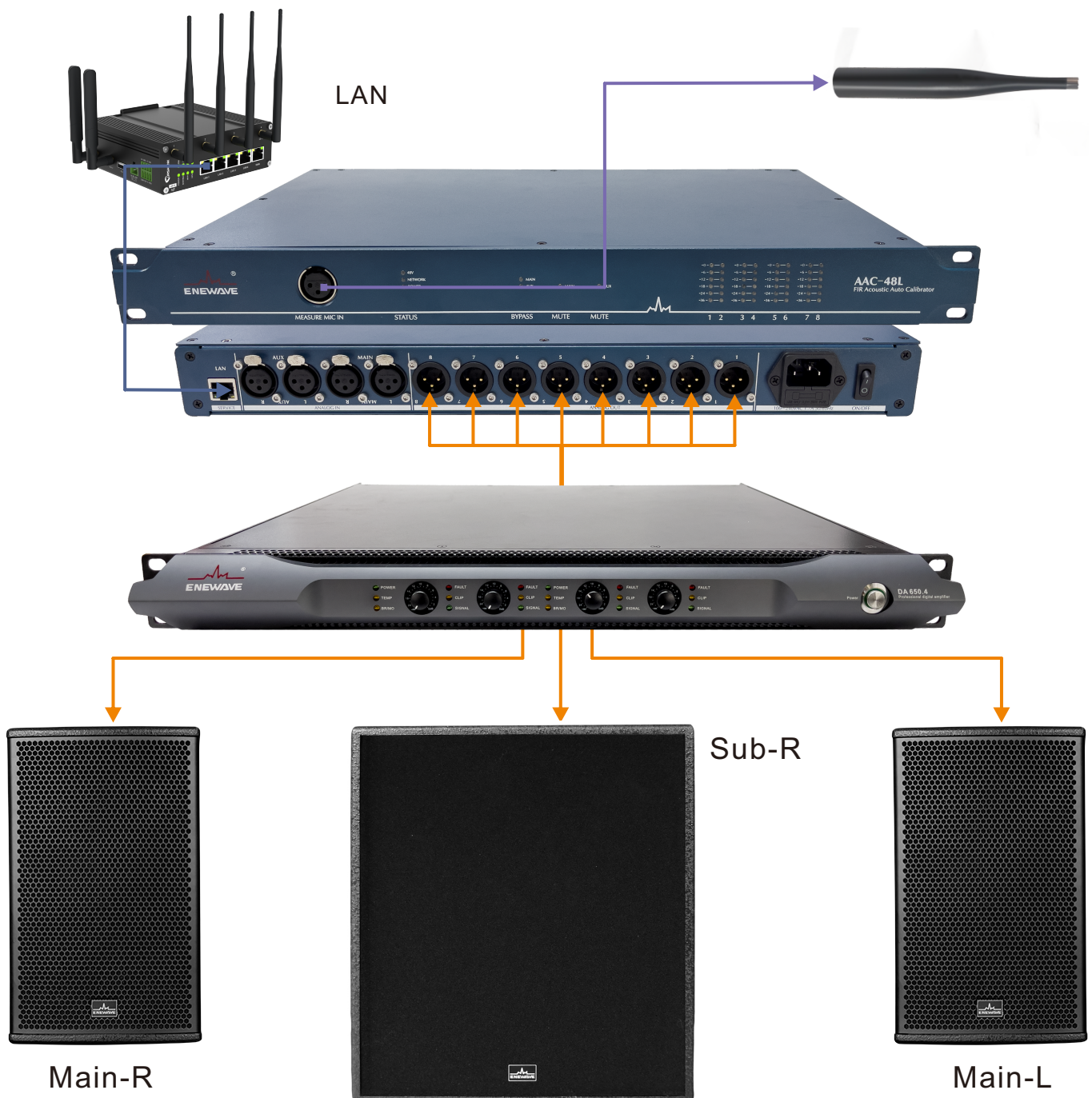



3 System configuration

3.1 Network connection

- Make sure your computer and AAC are connected to the same network, click "Connect".
- Click on the IP address after obtaining the IP address in the device status on the left, the power light turns green.

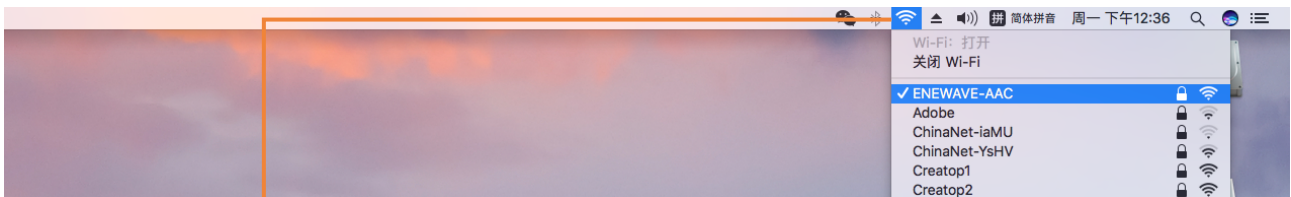

Set the computer's network settings and the AAC machine in the same network (same network segment: the last digit of the decimal point of the IP address is different, and the other digits are the same).



After confirming that AAC is turned on for one minute, click CONNECT to search the network.



When the AAC network address is displayed in the URL box, click on the network address. The network address and the power icon on the left are green, and the computer has been connected to AAC.



4 General function Introduction

4.1 Config speaker

Perform software settings according to the combination of speakers. For example, there is a pair of Stereo and one bass. First select the crossover option and drag the desired crossover position. Set the crossover point and crossover slope.

The screenshot shows the ENEWAVE AAC software interface with various components labeled for configuration:

- Measure mode selector:** Located at the top left, it includes a 'Measure Off' button and a '0 dB' indicator.
- SPL indicator:** A vertical scale on the left side showing signal levels from 0 to -60 dB.
- Drag to change the desired crossover point-green line:** A green vertical line on the 'FR&OVER' graph indicating the crossover frequency.
- Adjust the sweep signal:** A control for adjusting the sweep signal level.
- Front MIC 48V power:** A '48V' button and a 'CHECK' button for microphone power.
- Optional 5-point sweep frequency circle:** A set of five frequency points for sweep measurement.
- Reset and clear sweep frequency:** 'RESET' and 'COMPUTE MFIR' buttons.
- MFIR coefficient calculation:** 'MAIN GC' and 'ALX GC' sliders for gain compensation.
- Main input:** A control for the main input signal.
- Aux input:** A control for the auxiliary input signal.
- Shift mono or Stereo subwoofer:** A control for selecting between mono and stereo subwoofer modes.
- Crossover mode:** A control for selecting the crossover mode.
- Shift MFIR & LFIR:** 'MFIR' and 'LFIR' dropdown menus.
- Bypass & optimize:** 'PROCESS' buttons for bypassing or optimizing the signal.
- Compressor switch:** An 'ON/OFF' switch for the compressor.
- Ratio of compressor:** A 'Ratio' knob for setting the compressor ratio.
- Makeup gain:** A 'Makeup Gain' knob for adjusting the output level.
- Threshold value of compressor:** A 'Threshold (dB)' knob for setting the compressor threshold.
- Knee mode of attack:** A 'Knee' knob for setting the compressor knee.
- Release time of compressor:** A 'Release (ms)' knob for setting the release time.
- Attack time of compressor:** An 'Attack (ms)' knob for setting the attack time.



4.2 Click APPLY CROSSOVER to load the crossover application

After selecting, click APPLY CROSSOVER to load the application crossover. The output default 1.2 channel is SUB, 3-4 channel is HF. Connect the corresponding audio according to the default output of the interface.



1. Four different crossover mode to be shifted
2. When a subwoofer is connected, this setting selects MONO S. Two SUBs select STEREO S. It is used for calibration setting.
3. If there is a crossover, put the crossover point to the desired position. Click APPLY CROSSOVER

4.3 Connect the corresponding high and low frequency output

Connect the corresponding high and low frequency band output according to the default output matrix of the software. In the software, switch MEASURE OFF to MEASURE ON---turn on the sound---click RESET---turn on the CHECK sound to generate pink noise, adjust the SIGNAL fader to a suitable position---turn off the CHECK---select the sweep type (Stereo or mono).



1. The default option appears for output according to the setting of the crossover point, and the audio connected to the output is set according to this option. (According to Figure 1, 2 channels are connected to SUB. 3, 4 channels are connected to HF.)
2. Click CHECK speaker to generate pink noise, drag the fader to increase the volume of pink noise a little bit, so that the sound pressure level reaches the required level.
3. Sweep frequency setting can choose stereo and mono.



4.4 Sweep frequency

Sweep frequency to view the frequency response curve in FR&OVER. (The following figure). OK and click COMPUTE MFIR (the coefficient of MFIR is calibrated)



FR & XOVER

After sweeping, click to calculate MFIR coefficient (coefficient for spatial phase calibration)

The five points of the sweep are displayed on FR & XOVER's 1-5. Click to display the frequency response curve in yellow.

The frequency response curve of 5 sweep points can be viewed under FR & XOVER. According to the actual frequency sweep point, click the corresponding number to turn it into yellow. At this time, the frequency response curve is displayed. White curve left channel, red curve right channel. The selected check can also display the frequency response curve of L or R separately for multi-point comparison.

4.5 Click on the IMPLUSE interface

Click on the IMPLUSE interface, select (or other points, the selected point should represent the typical characteristics of the sound field phase, it is recommended to select the middle point.), a pulse line will appear. The display plus/minus to the appropriate size can be clearly displayed. Drag the green line to the start position of the pulse line and enter the corresponding sampling order in the input box below. A semi-transparent dashed frame will appear from the starting point. The box represents the end point of the pulse processing, and this end point needs to be set before the first reflection peak.

Pulse processing is calculated separately for L and R. After setting, click COMPUTE LFIR (linear phase FIR processing parameter, this parameter includes the frequency response setting in the CURVE curve). After the calculation is completed, follow these steps to process the R channel again. (The LFIR coefficient is calibrated).



Pulse curve after green line calculation.

Pulse obtained by white line sweep.

The yellow line is the comparison line with the green line after calculation.

When performing the BYPASS MFIR coefficient and LFIR coefficient switching comparison test, it is necessary to adjust the volume to the same level.

Adjust the green line to the start position of the pulse line. Select the corresponding sampling order according to the actual situation.

The corresponding sampling scale.

After adjustment, click COMPUTE LFIR to calculate the coefficient. (Note that the left and right channels must be calculated separately.)

The choice of left and right channel pulse signal.



4.6 Enter usage mode

Switch MEASURE ON to MEASURE OFF state to enter the use mode. The calibration is complete.

4.7 Use the CURVE interface to change the frequency amplitude

In the CURVE interface, you can change the amplitude of different frequencies in the target curve according to your own needs. You can also click the FLAT drop-down menu to select a different smoothing curve for frequency response optimization



- Drag the pink line to change the end position of the process.
- Double-click the left button of the mouse to specify the point, and hold it down to drag the desired range up or down.
- Drag the blue line to change the starting position of the process.
- Four modes selection
- Apply the set MFIR curve. LFIR setting application is loaded in the IMPLUSE interface COMPUTE LFIR application.
- Reset to the state of the initial line.

4.8 Corresponding display of phase

The original phase of the white line, the LFIR phase of the green line, and the MFIR phase of the yellow line.



- Apply the set MFIR curve. LFIR setting application is loaded in the IMPLUSE interface COMPUTE LFIR application.



4.9 About compressor settings



Select the use of different channel compressors and click ON/OFF

4.10 Correct output items

The output must use the default output option during calibration. After the calibration is completed, the output can be changed arbitrarily according to different needs.



According to the selection requirements of the input channel MAIN and AUX inputs, different outputs are selected.



4.11 Connection diagram of input and output

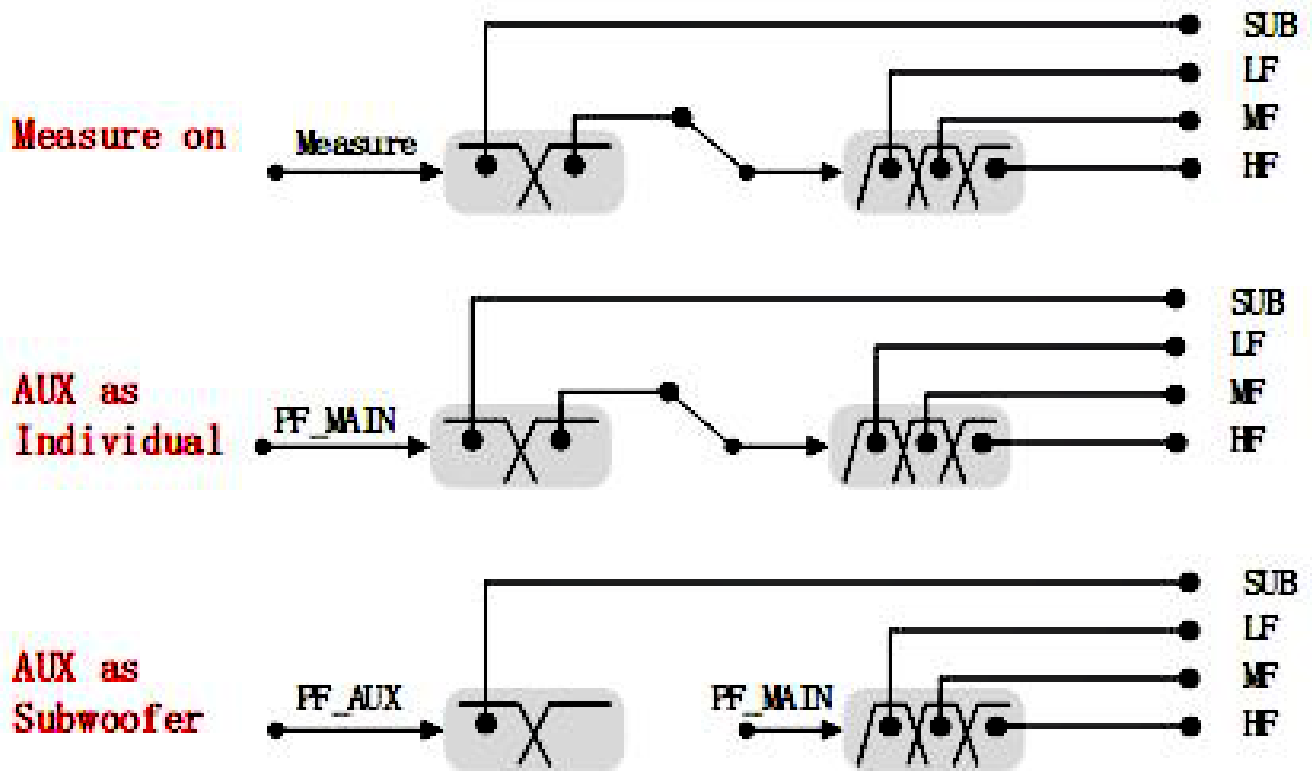



4.11 Connection diagram of input and output

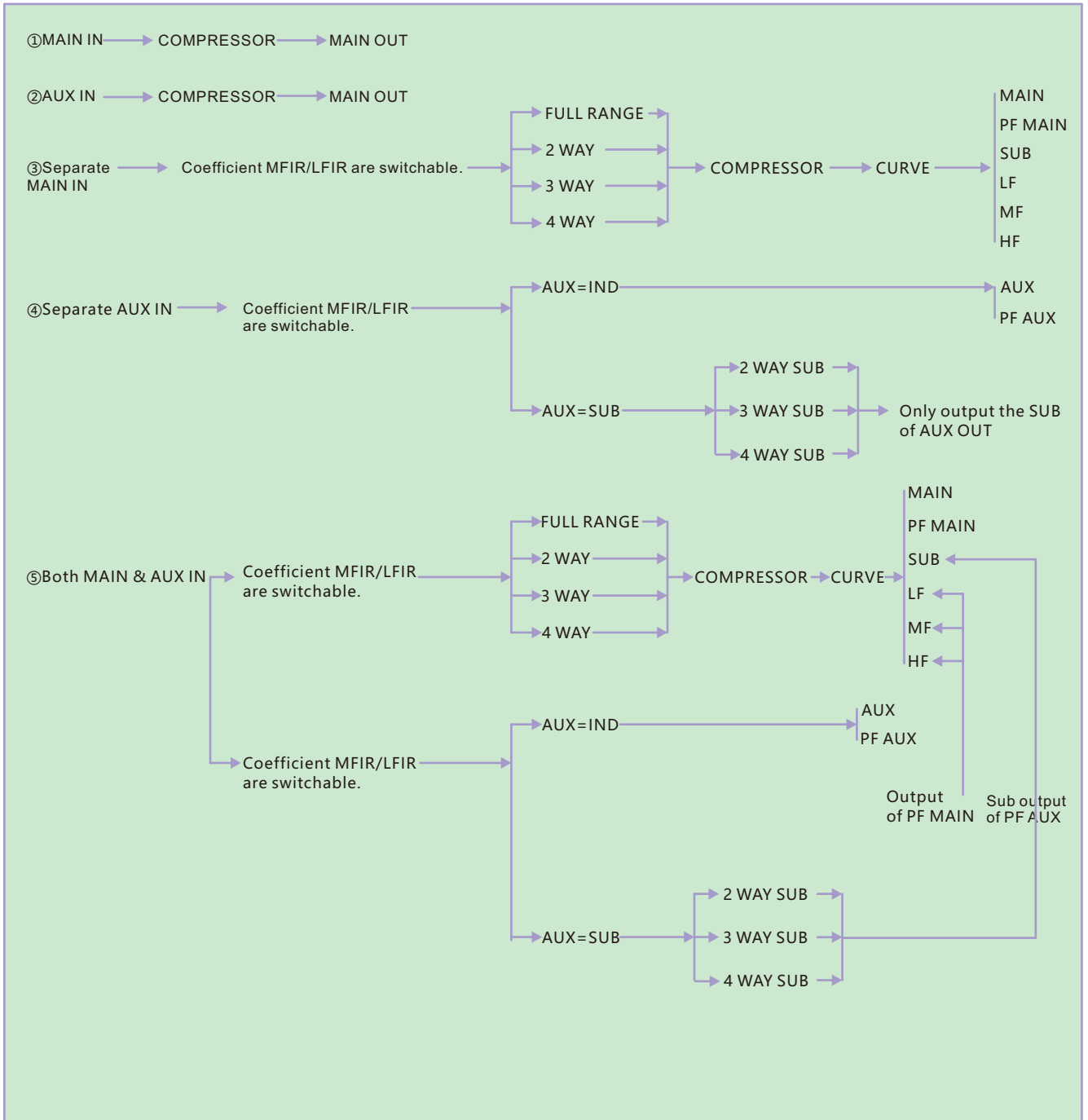



4.12 Save Settings

The calibrated settings can be saved.

The screenshot shows the AAC software interface with the CURVE menu open. The menu options are: Save Target Curve File, Load Target Curve File, Save Parameter File, and Load Parameter File. Callouts point to these options with the following text: "Save and load the curve of Curve" (pointing to Save/Load Target Curve File) and "Save and load the parameter file set by AAC" (pointing to Save/Load Parameter File). The background shows the frequency response graph with a peak at 796Hz.

The screenshot shows the AAC software interface with an error dialog box in the center that reads "Load failed, please retry again" with an "OK" button. A callout points to the dialog box with the text "Save and load the curve of Curve". The background shows the software interface with various settings and graphs.



5 Specifications

Sample rate	44.1、 48、 88.2、 96、 192 (kHz)
Analog input	4x XLR (L/R) , +24dBu max
Analog output	8x XLR (L/R,SUB, AUX) , +24dBu max
Digital input	1 x AES/EBU@75 Ohms
T.B.C. input	1x Input@75Ohms 3Vpp on BNC32-192kHz
T.B.C. output	1x Output@75Ohms 3Vpp on BNC32-192kHz
A/D converter	Dynamic range 120dB THD+N: -107dB
D/A converter	Dynamic range 120dB THD+N: -110dB
Amount latency	0.25ms
	FPGA processing architecture
	One-way AUX output
	4 x 4096 scales FIR filter

6 Misunderstandings and precautions during use

<1>, Why is there no output after calibration?

- ① After completing the calibration, MEASURE ON was not changed to MEASURE OFF.
- ② The output option does not correspond to the connection input.

<2>, After using the LFIR parameter to change the amplitude of the CURVE curve, why does the sound not change according to the change setting?

- ① After adding some changes, you need to select L and R respectively in IMPLUSE and click compute LFIR. (The curve of LFIR is loaded here).

<3>, Why the output channel settings are the same, but the output signal is different?

- ① One possibility is to check the compressor on the software, it is not the same whether the group of compressors is on or off.

<4>, Why sometimes the settings are not saved according to the previous settings after shutting down and restarting?

- ① The power was cut off unexpectedly when operating the software, and the operating command sent by the software to the hardware was not sent down.
- ② Do not shut down immediately after operating the software, wait for five seconds before shutting down.



<5>, Why the output options will be changed after clicking the MEASURE On test mode after setting the output options?

Reason After selecting the crossover setting, click APPLY CROSSOVER. Then you click MEASURE ON to enter the test mode. The test mode will have a default output. Need to connect the output line according to the default connection. After the test, change MEASURE ON to MEASURE OFF. The output can be changed and saved at will.



<6> After the crossover is set, the L and R frequency response curves of SUB are different after frequency sweeping?

① This situation may be a setting problem. If you only connect one speaker to the SUB, choose MONO-S. If the SUB is left and right channel stereo, choose STEREO-S. See the picture below.



7 Judgment and solution of failure

7.1 About the troubleshooting process of the AAC device and the AAC software cannot be connected

Check whether the AAC device is started after it is turned on and observe whether the network lights of the AAC and the router are normal. The judgment method is as follows:

Check the connection between the AAC and the router. The network interface has two indicators, which are the connection status indicator and the signal transmission indicator. In the normal state, the connection status indicator is green and steady, and the signal indicator is yellow. The normal state should be Keep blinking.

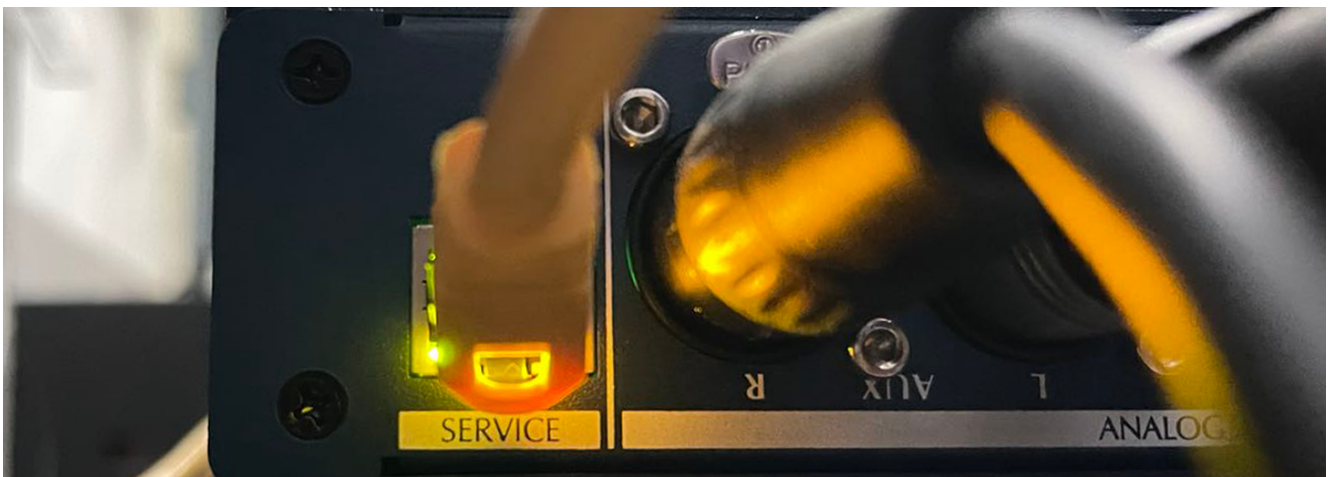

If you find the connection indicator, that is, the green light is off, it means that the connection between the APC and the router is faulty. If there is a fault, replace a good network cable or router. The yellow light is off, indicating that the transmission is faulty. The device can be restarted. If it is broken, it should be repaired by the relevant party.

7.2. If there is no problem with the hardware, the network still cannot be connected to the network. Check whether the operating computer, router and AAC are in the same network segment.



7.3, If the network firewall in the computer is turned on, please turn off the firewall and anti-virus software such as 360 or AAC software is allowed. After the AAC software is copied to the computer, the firewall will block it, and you need to click to allow the AAC software. If there is no prompt, it is still not connected to the network.

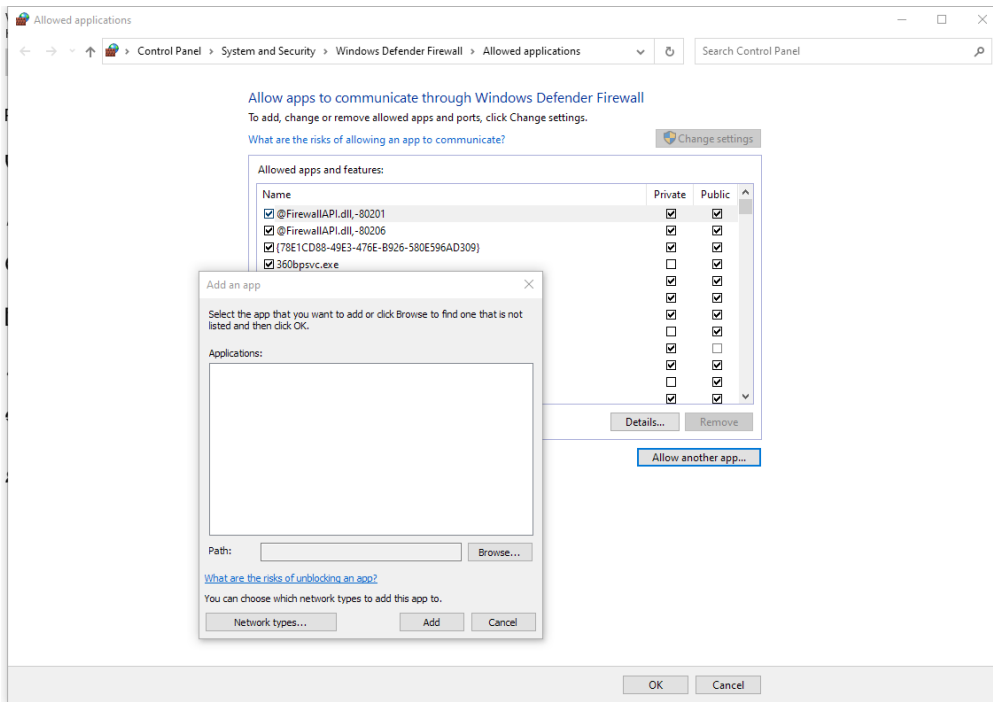

7.4 Check the firewall settings in the WIN10 system and add APC to it.

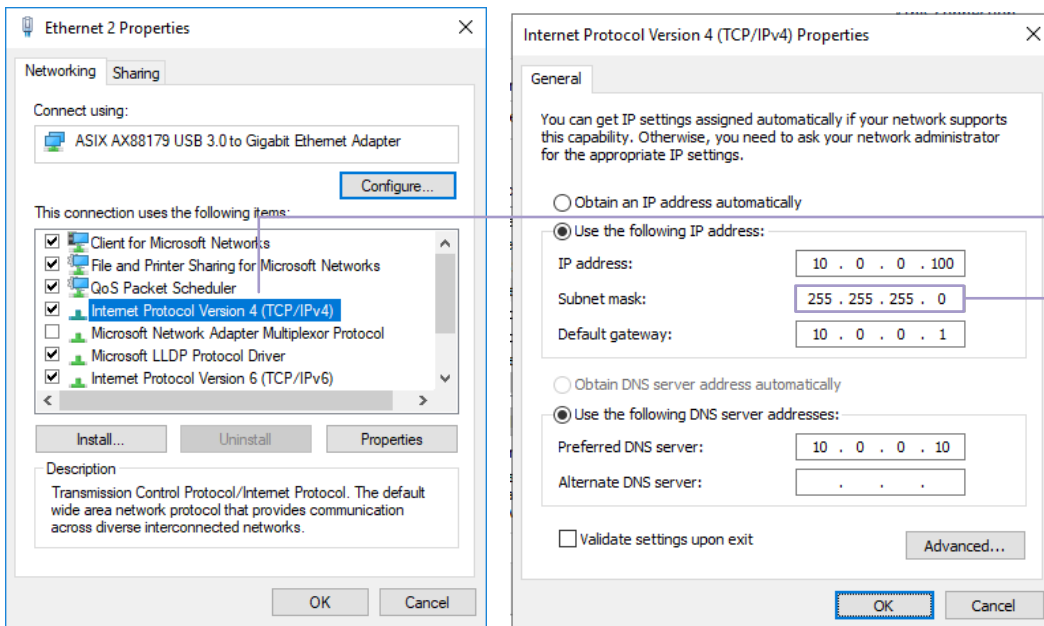

Find the INTERNET protocol version TCP/IPv4

View and change it to a unified network segment with the router.

7.5 PC desktop computers, AAC devices cannot be connected to the AAC software. If other wireless network cards are connected, the network card needs to be disabled, leaving only the local area network. Right-click to open the Network and Sharing Center-change adapter settings-change.

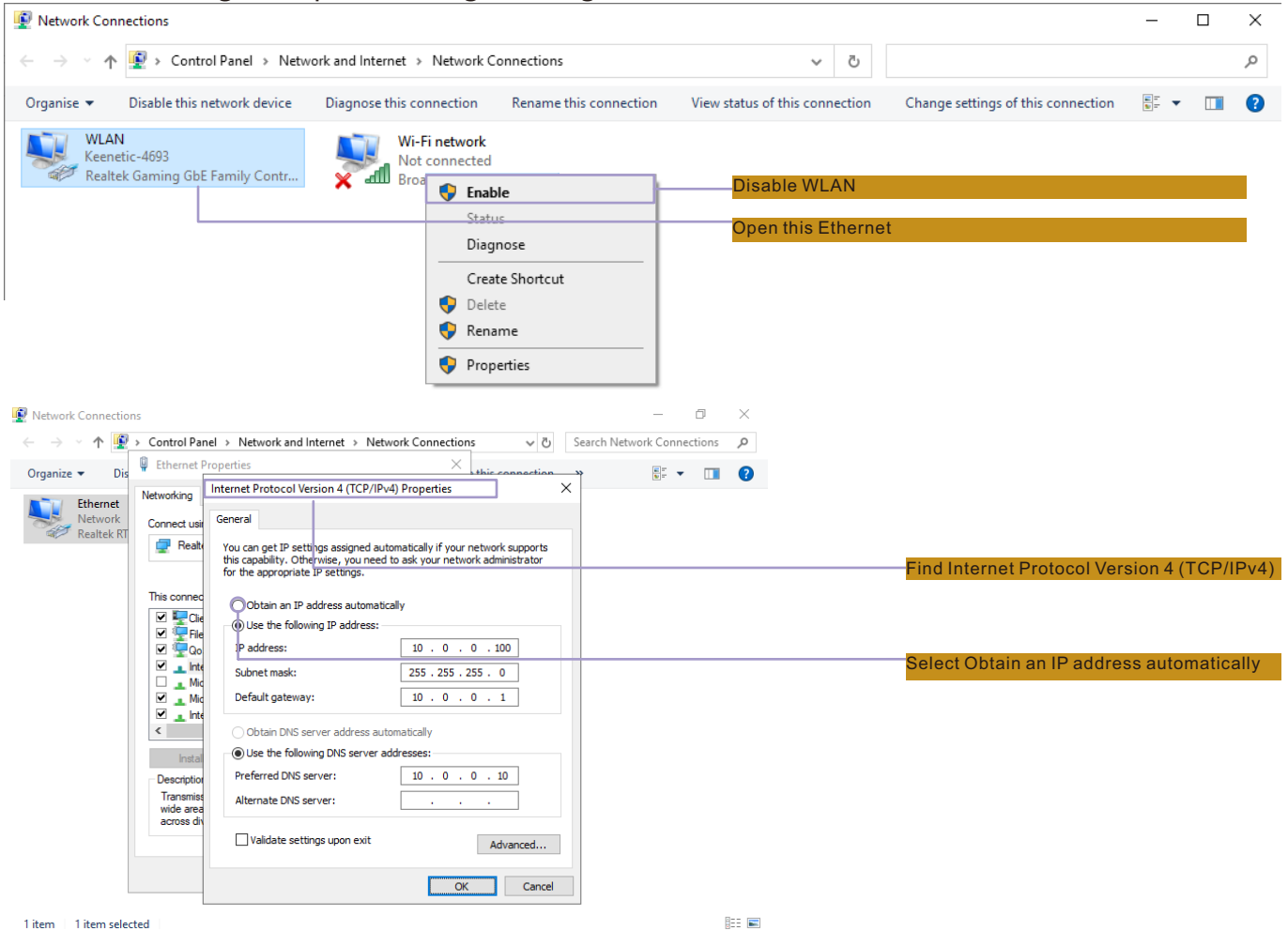

7.6 MAC computer, screen saver or device cannot connect with the software after sleep. How to solve this. When testing or applying software, put the wireless router first in the system preferences --- network - advanced. It can be solved.

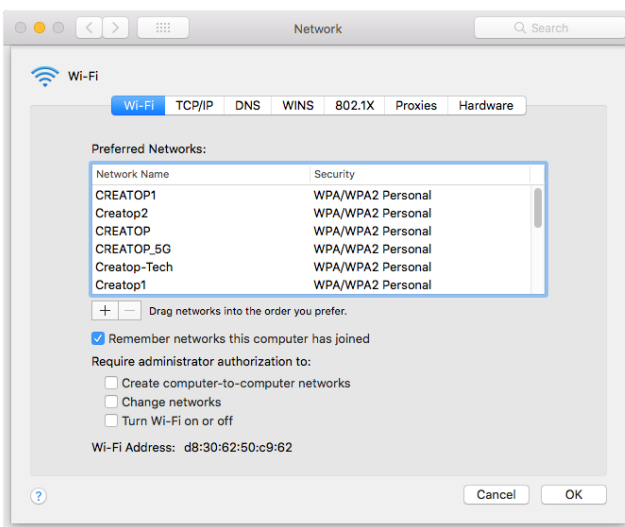



8 Real measurement environment

In order to simplify the operation process and obtain more scientific data, we used AAC equipment to measure in a real environment and obtained the following indicators for your reference.

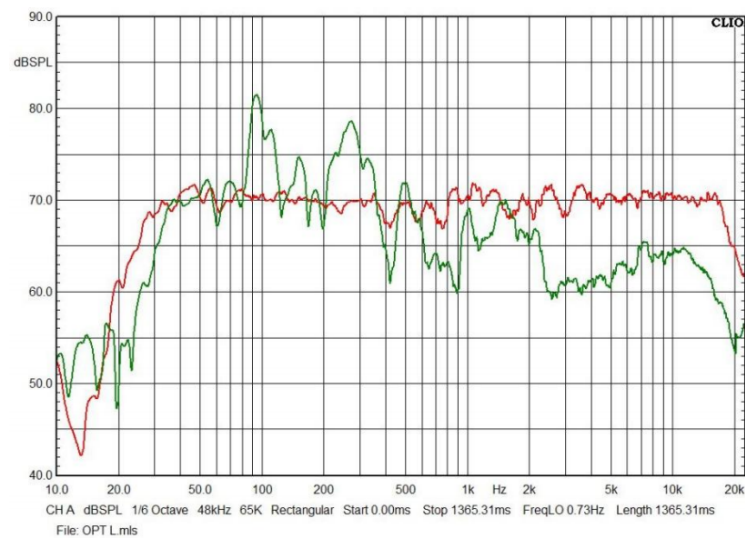
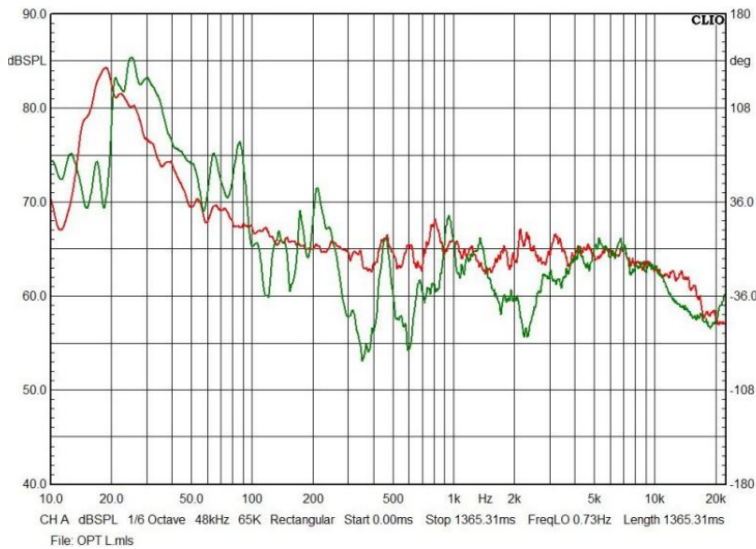

series products from the following channels. Our website has some of related technical documents and data manuals available for download. You can also contact us via E-mail.

<https://global.enuwave.com>

Email: gary_chou@enuwave.com

Tle:864-527-0433

Fax:864-288-4608



Enewave Electronics LLC

33 Market Point Dr. Greenville.

SC 29607, USA

Tel: 864-527-0433 Fax: 864-288-4608

Tel: +1-864-527-0433 Fax: +1-864-288-4608

Tel: +86-755-2602-8950 Fax: +86-755-2602-8954